

Model

VA4 RPBP



AIR Power supply
Compressed Air

The model VA4 RPBP is a **vacuum glass lifter specific for indoor use**, with four suction pads d. 310 mm, compressed air powered with lifting capacity 400Kg. The pads are replaceable along the arms; and the arms are replaceable along the central beam, which is long 1500 mm.

The lifter features **powered 90° rotation and powered 0 – 90° tilt**, thank to its pneumatic cylinders. Equipped with an audio-visual alarm control unit that warns the operator of possible dangerous situations.

This model is also available with suction pads d. 390 mm and lifting capacity 600kg.

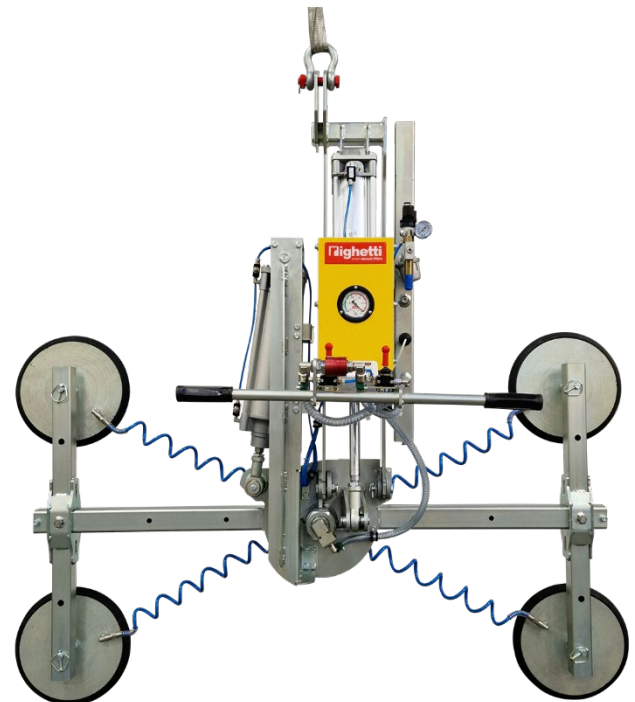

Technical specification

Application	Glass panels
Lifting capacity	Max 400 kg
Suction pads	No. 4 round suction pads diameter 310 mm Lipped pads with safety ring
Pad spread	Various pads configurations: Min spread about 815 x 725 mm Max spread about 1665 x 1005 mm
Load movement	90° pneumatic rotation 90° pneumatic tilt
Operating system	Compressed air
Vacuum system	Single vacuum circuit with vacuum reserve and non return valve
Weight of lifter	Kg 109
Control	Manual on off valve on the lifter's frame Release of the load by dual action security command A joystick for each movement placed on the lifter's handlebar
Standard features	Audible and visual low vacuum warning devices Vacuum gauge and vacuum filter Adjustable arms position + Adjustable pads position

Technical drawings

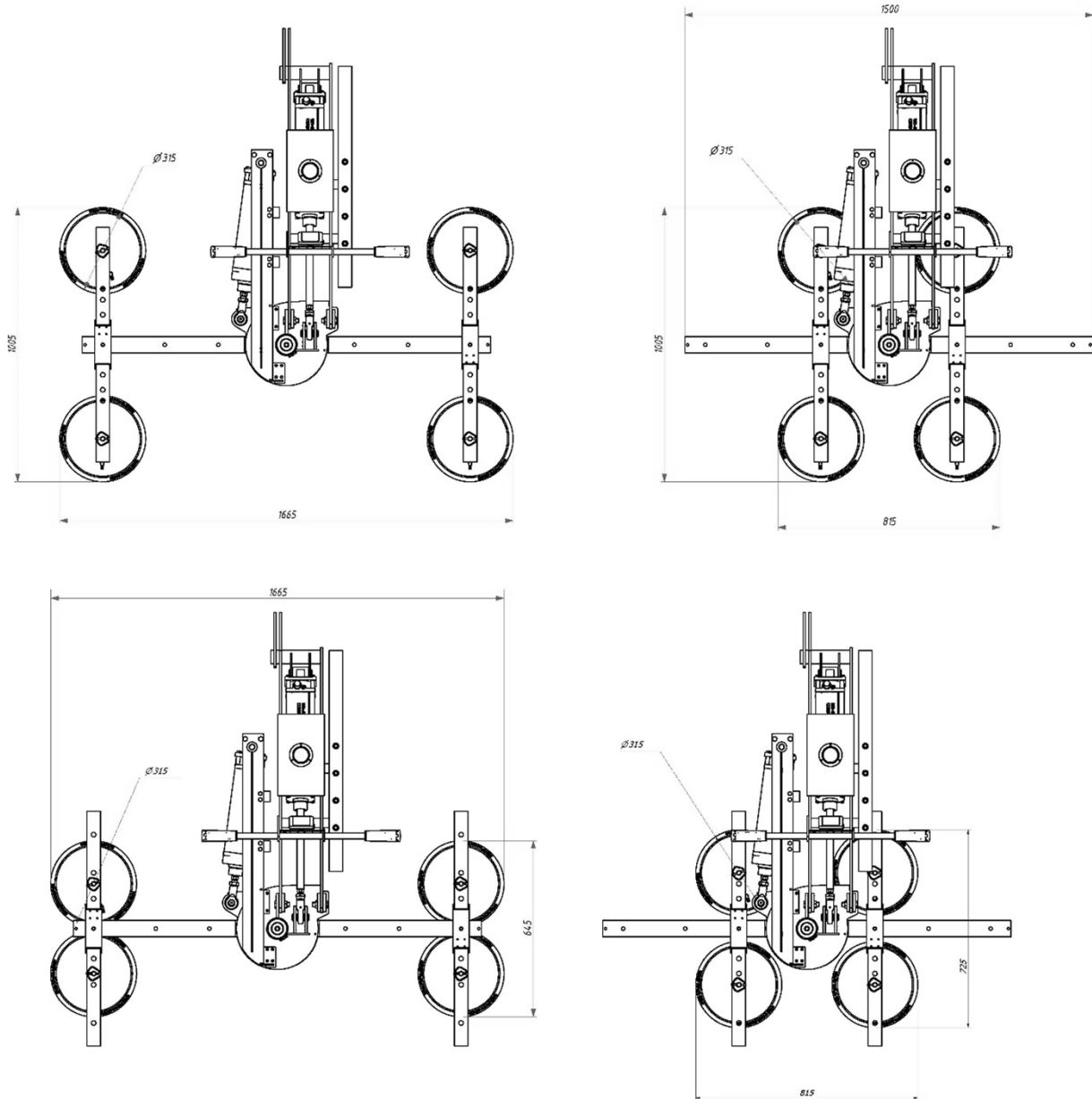

Pneumatic tilt 0-90°



Capacity max 400kg



Pneumatic rotation 90°



Safety devices



4 vacuum pads d.310 mm



Indoor use

CE

made in
ITALY