

Vacuum Stone Lifter serie O2B

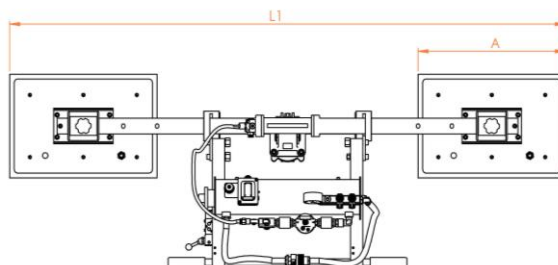

Technical specification

Application	Not porous stones
Lifting capacity	Up to 1500 kg
Suction pads	No. 2 rectangular suction pads
Load movement	0-90° oil dynamic tilt (horizontal/vertical)
Operating system	DC vacuum pump powered by on board batteries High capacity re-chargeable batteries Battery gauge
Vacuum system	Vacuum circuit, complete of vacuum reserve and non return valve
Weight of lifter	Depends on the configuration
Control	Slider valve for suction/release on the lifter release of the load by dual action security command
Standard features	On-off double sliding valve with safety Audible and visual low vacuum warning devices Vacuum gauge with colored scale

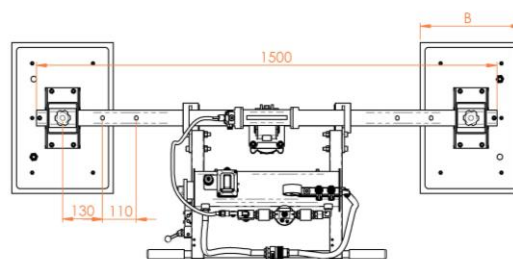
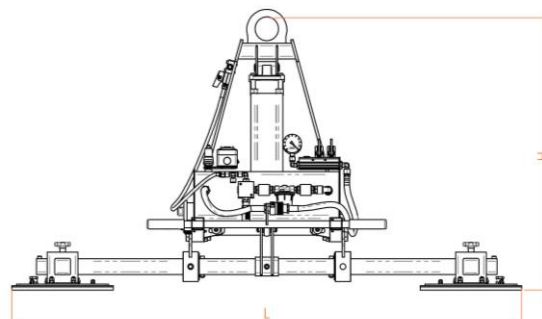

- self battery powered
- 2 suction pads
- oil dynamic tilting system
- lifting capacity up to 1.500 kg
- low vacuum warning device

Available models

Product code	Lifting capacity	A	B	H
O2B 250	250	480	230	
O2B 500	500	480	330	
O2B 700	700	630	330	
O2B 1000	1000	630	430	
O2B 1500	1500	830	480	

