

Vacuum Stone Lifter serie M4B

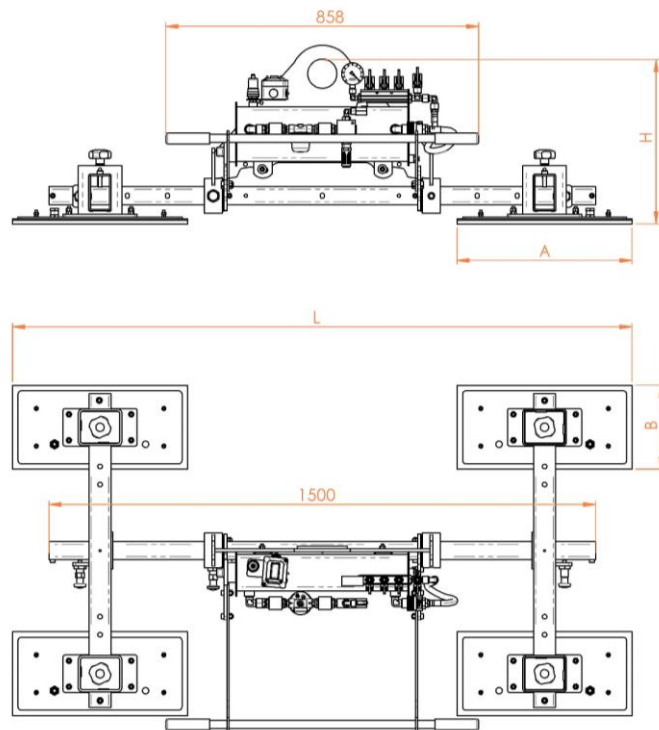

Technical specification

Application	Not porous stones
Lifting capacity	Up to 2000 kg
Suction pads	No. 4 rectangular suction pads
Load movement	0-90° manual tilt (horizontal/vertical)
Operating system	DC vacuum pump powered by on board batteries High capacity re-chargeable batteries Battery gauge
Vacuum system	Vacuum circuit, complete of vacuum reserve and non return valve
Weight of lifter	Depends on the configuration
Control	Slider valve control for suction/release on the lifter release of the load by dual action security command
Standard features	On-off double sliding valve with safety Audible and visual low vacuum warning devices Vacuum gauge with colored scale Battery charger 240 Volt



- self battery powered
- 4 suction pads
- tilting system from horizontal to vertical
- lifting capacity up to 2.000 kg
- low vacuum warning device

Available models

Product code	Lifting capacity	A	B	H
M4B 500	500	480	230	450
M4B 1000	1000	480	330	450
M4B 1500	1500	630	330	450
M4B 2000	2000	630	430	450

