

Vacuum Metal Sheet Lifter serie FS-EB

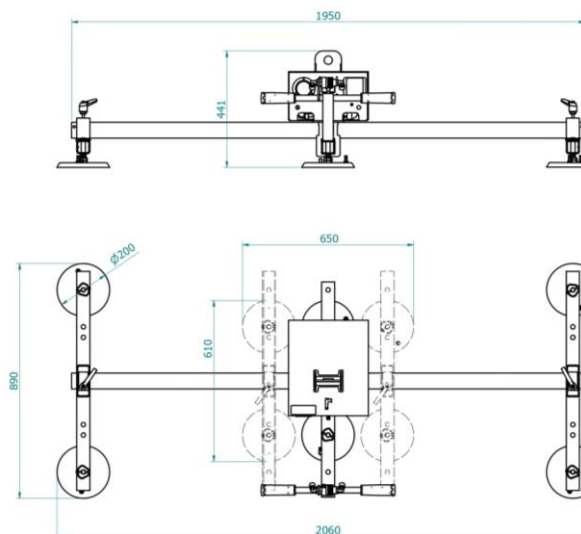

Technical specification

Application	Metal sheet, stainless steel, aluminum, plastic panels
Lifting capacity	250 kg on mod. FS4EB 250 / 500 kg on mod. FS6EB 500
Suction pads	Nr.4 pads on model FS4EB / nr. 6 pads on model FS6EB Suction pads in vulcanized rubber, diameter 200 mm Suction pads with spring supports Exclusion of suction pads by cross arm
Frame	Steel frame structure fixed in horizontal position Lowered below the hook high The suction pads are distributed on cross arms Adjustable position of suction pads and of cross arms
Operating system	Electric 400V 3 phase 50Hz or 220V 1 phase 50Hz > to specify at order
Vacuum system Safety systems	Vacuum circuit with vacuum reservoir, non-return valve, vacuum filter Vacuum gauge with colored scale Audio visual low vacuum warning powered independently and with back up battery
Weight of lifter	Depends on the configuration
Command	Suction and release by slide valve command with safety system



- **Electric operating system**
- 4 suction pad d.200 mm on FS4EB
6 suction pad d.200 mm on FS6EB
- fixed frame for horizontal lifting
- low below the hook high
- lifting capacity 250 kg on FS4EB
lifting capacity 500 kg on FS6EB

Available models

Serie FS4EB 250 250 Kg

Pads		Capacity	L	Arms		X (mm)		Y (mm)		Product code
nr.	Ø	kg	mm	nr.	mm	min	max	min	max	
4	200	250	1950	2	750	650	2060	610	890	FS4EB 250

Serie FS6EB 500 500 Kg

Pads		Capacity	L	Arms		X (mm)		Y (mm)		Product code
nr.	Ø	kg	mm	nr.	mm	min	max	min	max	
6	200	500	1950	3	750	650	2060	610	890	FS6EB 500

