

Vacuum Metal Sheet Lifter serie F4EB 600

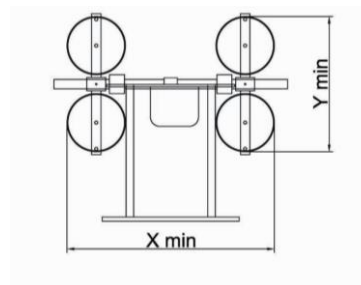

Technical specification

Application	Metal sheet, stainless steel, aluminum, plastic panels
Lifting capacity	600 kg
Suction pads	No. 4 suction pads in vulcanized rubber, diameter 310 mm Suction pads with spring supports Exclusion of suction pads by cross arm
Frame	Steel frame structure fixed in horizontal position The suction pads are distributed on two cross arms Adjustable position of suction pads and of cross arms
Operating system	Electric 400V 3 phase 50Hz or 220V 1 phase 50Hz > to specify at order
Vacuum system Safety systems	Vacuum circuit with vacuum reservoir, non-return valve, vacuum filter Vacuum gauge with colored scale Audio visual low vacuum warning powered independently and with back up battery
Weight of lifter	Depends on the configuration
Command	Suction and release by slide valve command with safety system

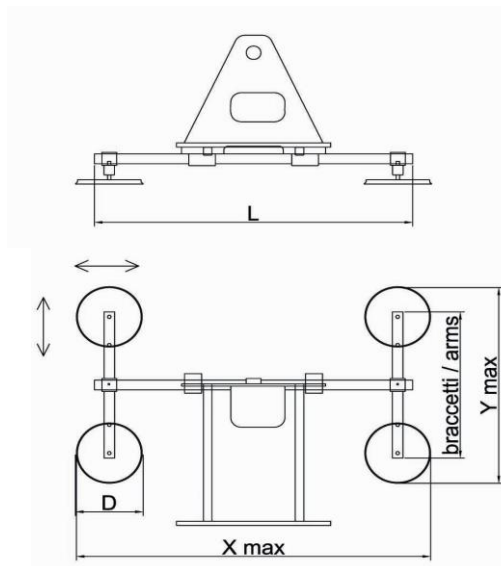

- Electric operating system
- 4 suction pad d.310 mm
- fixed frame for horizontal lifting
- lifting capacity 600 kg
- Safety devices

Available models

Piastre pads		Portata capacity kg	L mm	Braccetti arms		X (mm)		Y (mm)		Codice prodotto Product code
nr.	Ø			nr.	mm	min	max	min	max	
4	310	600	1500	2	750	1100	1650	720	1000	F4EB600/3-1500/750
						1100	2150	720	1000	F4EB600/3-2000/750
			2000	2	750	1100	2150	720	1500	F4EB600/3-2000/1270
						1100	3150	720	1000	F4EB600/3-3000/750
3000	2	750	1100	3150	720	1500	F4EB600/3-3000/1270			

