

# Vacuum Metal Sheet Lifter serie F4B 600

## Technical specification

Application	Metal sheet, stainless steel, aluminum, plastic panels
Lifting capacity	600 kg
Suction pads	No. 4 suction pads in vulcanized rubber, diameter 310 mm Suction pads with spring supports Exclusion of suction pads by cross arm
Frame	Steel frame structure fixed in horizontal position The suction pads are distributed on two cross arms Adjustable position of suction pads and of cross arms
Operating system	DC vacuum pump powered from on-board batteries high capacity re-chargeable batteries battery status indicator economizer for reduction of the energy consumption battery charger included
Vacuum system Safety systems	Vacuum circuit with vacuum reservoir, non-return valve, vacuum filter Vacuum gauge with colored scale Audio visual low vacuum warning powered independently and with back up battery
Weight of lifter	Depends on the configuration
Command	Suction and release by slide valve command with safety system

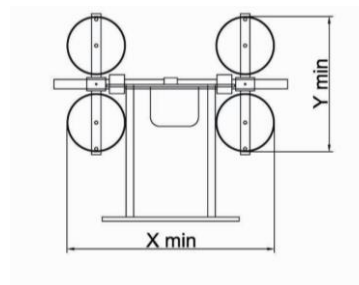
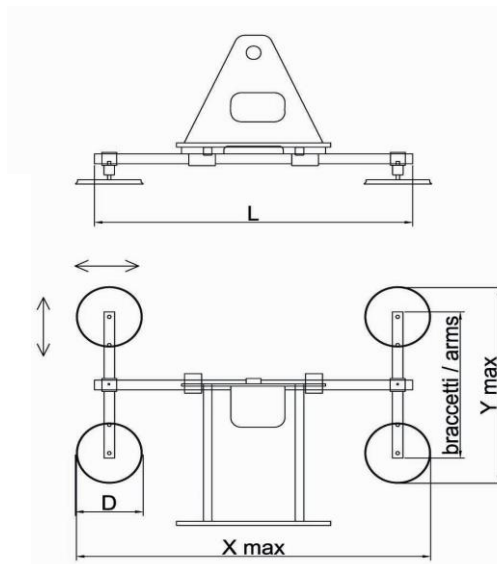

**Righetti**  
smart vacuum lifters

- **Battery operating system**
- 4 suction pad d.310 mm
- fixed frame for horizontal lifting
- lifting capacity 600 kg
- Safety devices

## Available models

pads		capacity	L	arms		X (mm)		Y (mm)		Product code
nr.	∅	kg	mm	nr.	mm	min	max	min	max	
<b>4</b>	<b>310</b>	<b>600</b>	<b>1500</b>	<b>2</b>	<b>750</b>	<b>1100</b>	<b>1650</b>	<b>720</b>	<b>1000</b>	<b>F4B600/3-1500/750</b>
						2000	2150	720	1000	F4B600/3-2000/750
			3000	2	750	1100	3150	720	1000	F4B600/3-3000/750
							1270	3150	720	1500

